



SPECIFICATIONS

GENERAL SPECIFICATIONS

Model	XJR1300(L)
Model code:	5EA2/5EA3/5EA4
Dimensions:	
Overall length	2175 mm (GB) (D) (NL) (B) (F) (E) (P) (I) (GR) (SF) (AUS)
Overall width	775 mm
Overall height	1115 mm
Seat height	775 mm
Wheelbase	1500 mm
Minimum ground clearance	120 mm
Minimum turning radius	2800 mm
Basic weight:	
With oil and full fuel tank	253 kg
Engine:	
Engine type	Air-cooled 4-stroke, DOHC
Cylinder arrangement	Forward-inclined parallel 4-cylinder
Displacement	1250 cm ³
Bore × stroke	79.0 × 63.8 mm
Compression ratio	9.7: 1
Compression pressure (STD)	1050 kPa (10.5 kg/cm ² , 10.5 bar) at 400 r/min
Starting system	Electric starter
Lubrication system:	Wet sump
Oil type or grade:	SE or higher grade
Engine oil	
<p>Temp. °C</p> <p>10W/30</p> <p>10W/40</p> <p>20W/40</p> <p>20W/50</p> <p>11750703</p>	
Engine oil	
Periodic oil change	3.0 L
With oil filter replacement	3.35 L
Total amount	4.2 L
Oil cooler capacity (including all routes)	0.2 L
Air filter:	Dry type element
Fuel:	
Type	Regular unleaded gasoline
Fuel tank capacity	21 L
Fuel reserve amount	4.5 L

GENERAL SPECIFICATIONS

SPEC



Model	XJR1300(L)
Carburetor: Type/quantity Manufacturer	BS36/4 MIKUNI
Spark plug: Type × quantity Manufacturer Spark plug gap	DPR8EA-9/X24EPR-U9 × 4 NGK/DENSO 0.8 ~ 0.9 mm
Clutch type:	Wet, multiple-disc
Transmission: Primary reduction system Primary reduction ratio Secondary reduction system Secondary reduction ratio Transmission type Operation Gear ratio 1st 2nd 3rd 4th 5th	Spur gear 98/56 (1.750) Chain drive 38/17 (2.235) Constant mesh 5-speed Left foot operation 40/14 (2.857) 36/18 (2.000) 33/21 (1.571) 31/24 (1.292) 29/26 (1.115)
Chassis: Frame type Caster angle Trail	Double cradle 25.5° 100 mm
Tire: Type Size front rear Manufacturer front rear Type front rear	Tubeless 120/70ZR17 (58W) 180/55ZR17 (73W) MICHELIN/DUNLOP/BRIDGESTONE MICHELIN/DUNLOP/BRIDGESTONE MACADAM 90X/D207F/BT57F MACADAM 90X/D207/BT57R
Tire pressure (cold tire): Maximum load-except motorcycle Loading condition A * front rear Loading condition B * front rear High-speed riding front rear	207 kg 0 ~ 90 kg 250 kPa (2.5 kg/cm ² , 2.5 bar) 250 kPa (2.5 kg/cm ² , 2.5 bar) 90 ~ 207 kg 250 kPa (2.5 kg/cm ² , 2.5 bar) 290 kPa (2.9 kg/cm ² , 2.9 bar) 250 kPa (2.5 kg/cm ² , 2.5 bar) 290 kPa (2.9 kg/cm ² , 2.9 bar)

*Load is the total weight of cargo, rider, passenger, and accessories.

GENERAL SPECIFICATIONS

SPEC



Model	XJR1300(L)
Brake: Front brake type operation Rear brake type operation	Dual disc brake Right hand operation Single disc brake Right foot operation
Suspension: Front suspension Rear suspension	Telescopic fork Swingarm
Shock absorber: Front shock absorber Rear shock absorber	Coil spring/Oil Damper Coil spring/Gas-oil damper
Wheel travel: Front wheel travel Rear wheel travel	130 mm 110 mm
Electrical: Ignition system Generator system Battery type Battery capacity	T.C.I. (Digital) A.C. generator GT14B-4 12 V 12AH
Headlight type:	Halogen bulb
Bulb wattage × quantity: Headlight Auxiliary light Tail/brake light Flasher light Meter light Neutral indicator light High beam indicator light Oil level indicator light Turn indicator light	12 V 60 W/55 W × 1 12 V 4 W × 1 12 V 5 W/21 W × 2 12 V 21 W × 4 12 V 1.7 W × 4 12 V 1.7 W × 1 12 V 3.4 W × 1 12 V 1.7 W × 1 12 V 1.7 W × 2

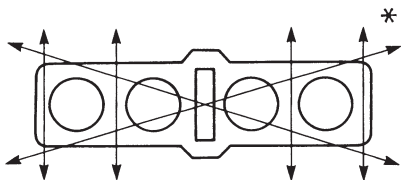
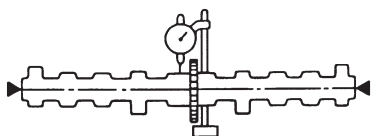

MAINTENANCE SPECIFICATIONS ENGINE

Model	Standard	Limit
Cylinder head: Warp limit 	●●●	0.1 mm
Cylinder: Bore size Taper limit Out of round limit Wear limit	79.00 ~ 79.01 mm ●●● ●●● ●●●	●●● 0.05 mm 0.05 mm 79.1 mm
Camshaft: Drive method Cam cap inside diameter Camshaft outside diameter Shaft-to-cap clearance Cam dimensions Intake "A" "B" "C" Exhaust "A" "B" "C" Camshaft runout limit 	Chain drive (Center) 25.000 ~ 25.021 mm 24.967 ~ 24.980 mm 0.020 ~ 0.054 mm 35.95 ~ 36.05 mm 28.248 ~ 28.348 mm 7.95 ~ 8.05 mm 35.95 ~ 36.05 mm 28.248 ~ 28.348 mm 7.95 ~ 8.05 mm ●●●	●●● ●●● ●●● ●●● 35.85 mm 28.15 mm ●●● 35.85 mm 28.15 mm ●●● 0.03 mm

MAINTENANCE SPECIFICATIONS

SPEC

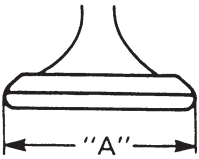
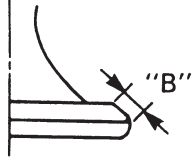
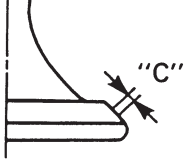
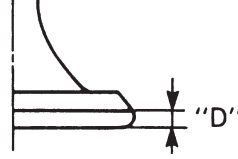
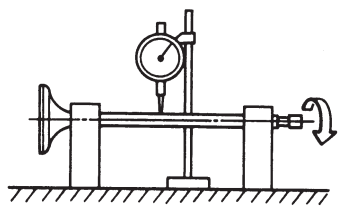

Model	Standard	Limit	
Cam chain:			
Cam chain type/No. of links	79RH2015/156	•••	
Cam chain adjustment method	Automatic	•••	
Valve, valve seat, valve guide:			
Valve clearance (cold)	IN 0.11 ~ 0.15 mm EX 0.16 ~ 0.20 mm	••• •••	
Valve dimensions:			
 <p style="text-align: center;">"A"</p>	 <p style="text-align: center;">"B"</p>	 <p style="text-align: center;">"C"</p>	 <p style="text-align: center;">"D"</p>
Head Dia.	Face Width	Seat Width	Margin Thickness
"A" head diameter	IN 28.9 ~ 29.1 mm EX 24.9 ~ 25.1 mm	••• •••	••• •••
"B" face width	IN 1.98 ~ 2.55 mm EX 1.98 ~ 2.55 mm	••• •••	••• •••
"C" seat width	IN 0.9 ~ 1.1 mm EX 0.9 ~ 1.1 mm	••• •••	••• •••
"D" margin thickness	IN 0.8 ~ 1.2 mm EX 0.8 ~ 1.2 mm	••• •••	••• •••
Stem outside diameter	IN 5.475 ~ 5.490 mm EX 5.460 ~ 5.475 mm	5.445 mm 5.43 mm	
Guide inside diameter	IN 5.500 ~ 5.512 mm EX 5.500 ~ 5.512 mm	5.552 mm 5.552 mm	
Stem-to-guide clearance	IN 0.010 ~ 0.037 mm EX 0.025 ~ 0.052 mm	0.08 mm 0.1 mm	
Stem runout limit	•••	0.01 mm	
			
Valve seat width	IN 0.9 ~ 1.1 mm EX 0.9 ~ 1.1 mm	1.6 mm 1.6 mm	

MAINTENANCE SPECIFICATIONS

SPEC



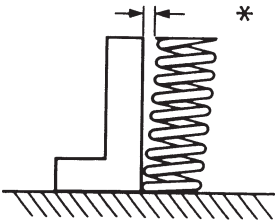
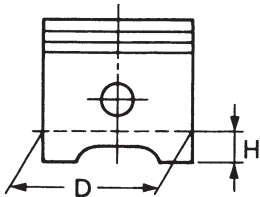

Model	Standard	Limit
Valve spring: Inner spring Free length Set length (valve closed) Compressed pressure (installed) Tilt limit 	IN 39.65 mm EX 39.65 mm IN 32.8 mm EX 32.8 mm IN 61.7 ~ 72.5 N (6.29 ~ 7.39 kg) EX 61.7 ~ 72.5 N (6.29 ~ 7.39 kg) IN ... EX ...	37.5 mm 37.5 mm 2.5°/1.7 mm 2.5°/1.7 mm
Direction of winding (top view) Outer spring Free length Set length (valve closed) Compressed pressure (installed) Tilt limit Direction of winding (top view)	IN Clockwise EX Clockwise IN 41.1 mm EX 41.1 mm IN 34.8 mm EX 34.8 mm IN 130.4 ~ 154.0 N (13.3 ~ 15.7 kg) EX 130.4 ~ 154.0 N (13.3 ~ 15.7 kg) IN ... EX ... IN Counterclockwise EX Counterclockwise 39 mm 39 mm 2.5°/1.7 mm 2.5°/1.7 mm
Piston: Piston to cylinder clearance Piston size "D" 	0.015 ~ 0.040 mm 78.970 ~ 78.985 mm	0.15 mm ...
Measuring point "H" Piston off-set Piston off-set direction Piston pin bore inside diameter Piston pin outside diameter	2 mm 1 mm IN side 18.004 ~ 18.015 mm 17.991 ~ 18.000 mm

MAINTENANCE SPECIFICATIONS

SPEC

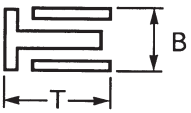
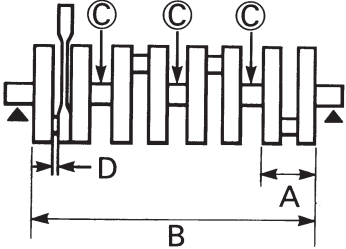

Model	Standard	Limit
<p>Piston rings: Top ring:</p>  <p>Type Dimensions (B × T) End gap (installed) Side clearance (installed)</p> <p>2nd ring:</p>  <p>Type Dimensions (B × T) End gap (installed) Side clearance (installed)</p> <p>Oil ring:</p>  <p>Dimensions (B × T) End gap (installed) Side clearance</p>	<p>Barrel 1.00 × 3.05 mm 0.20 ~ 0.35 mm 0.045 ~ 0.080 mm</p> <p>Taper 1.2 × 3.0 mm 0.35 ~ 0.50 mm 0.03 ~ 0.07 mm</p> <p>2.5 × 2.9 mm 0.2 ~ 0.5 mm 0.050 ~ 0.155 mm</p>	<p>••• ••• 0.6 mm 0.1 mm</p> <p>••• ••• 0.75 mm 0.1 mm</p> <p>••• ••• •••</p>
<p>Connecting rod: Oil clearance</p>	0.017 ~ 0.040 mm	0.08 mm
<p>Crankshaft:</p>  <p>Crank width "A" Assembly width "B" Runout limit "C" Big end side clearance "D" Journal oil clearance</p>	<p>62.25 ~ 63.85 mm 382.0 ~ 383.2 mm 0.02 mm 0.160 ~ 0.262 mm 0.030 ~ 0.064 mm</p>	<p>••• ••• ••• 0.5 mm 0.09 mm</p>

MAINTENANCE SPECIFICATIONS

SPEC

Model	Standard	Limit
Clutch:		
Friction plate thickness	2.9 ~ 3.1 mm	2.8 mm
Quantity	8 pcs	•••
Clutch plate thickness	1.9 ~ 2.1 mm	0.1 mm
Quantity	7 pcs	<Warp limit> •••
Clutch spring height	6 mm	•••
Quantity	1 pc	•••
Clutch housing thrust clearance	0 ~ 0.2 mm	•••
Clutch housing radial clearance	0.004 ~ 0.048 mm	0.1 mm
Clutch release method	Hydraulic inner push	•••
Push rod bending limit	•••	0.3 mm
Transmission:		
Main axle deflection limit	•••	0.06 mm
Drive axle deflection limit	•••	0.06 mm
Shifter:		
Shifter type	Guide bar	•••
Guide bar bending limit	•••	0.1 mm
Carburetor:		
I.D. mark	5EA1 10	•••
Main jet (M.J)	#95	•••
Main air jet (M.A.J)	#45	•••
Jet needle (J.N)	5D96-2	•••
Needle jet (N.J)	Y-2	•••
Pilot jet (P.A.J.1)	#127.5	•••
Pilot outlet (P.O)	0.85	•••
Pilot jet (P.J)	#40	•••
Bypass 1 (B.P.1)	0.9	•••
Bypass 2 (B.P.2)	1.0	•••
Bypass 3 (B.P.3)	0.8	•••
Pilot screw (P.S)	1-1/2	•••
Valve seat size (V.S)	2.3	•••
Starter jet (G.S.1)	#32.5	•••
Starter jet (G.S.2)	0.6	•••
Throttle valve size (Th.V)	#125	•••
Float height (F.H)	21.3 ~ 23.3 mm	•••
Fuel level (using special tool)	3.5 ~ 4.5 mm	•••
Engine idle speed	1000 ~ 1100 r/min	•••
Intake vacuum	31.3 kPa (235 mmHg)	•••

MAINTENANCE SPECIFICATIONS

SPEC







Model	Standard	Limit
Lubrication system:		
Oil filter type	Paper type	•••
Oil pump type	Trochoid type	•••
Tip clearance	0.12 ~ 0.17 mm	0.2 mm
Housing and rotor clearance	0.03 ~ 0.08 mm	0.15 mm
Side clearance	0.03 ~ 0.08 mm	0.15 mm
Bypass valve setting pressure	180 ~ 220 kPa (1.8 ~ 2.2 kg/cm ² , 1.8 ~ 2.2 bar)	•••
Relief valve operating pressure	480 ~ 580 kPa (4.8 ~ 5.8 kg/cm ² , 4.8 ~ 5.8 bar)	•••
Oil pressure (hot)	80 kPa (0.8 kg/cm ² , 0.8 bar) at 1000 r/min	•••
Pressure check location	MAIN GALLERY	•••

MAINTENANCE SPECIFICATIONS

SPEC



Tightening torques

Part to be tightened	Part name	Thread size	Q'ty	Tightening torque		Remarks
				Nm	m•kg	
Camshaft cap	Bolt	M6 × 1.0	18	12	1.2	
Oil gallery bolt	Screw	M6 × 1.0	1	7	0.7	
Spark plug	–	M12 × 1.25	4	18	1.8	
Cylinder head	Cap nut	M10 × 1.25	12	35	3.5	
Cylinder head cover	Bolt	M6 × 1.0	8	10	1.0	
Cylinder	Stud bolt	M8 × 1.25	1	8	0.8	
Cylinder	Nut	M8 × 1.25	3	20	2.0	
Cylinder	Nut	M6 × 1.0	6	10	1.0	
Connecting rod	Nut	M8 × 0.75	8	36	3.6	
Cam sprocket	Bolt	M7 × 1.0	4	20	2.0	
Timing chain tensioner	Bolt	M6 × 1.0	2	10	1.0	
Timing chain tensioner cap bolt	Bolt	M11 × 1.0	1	20	2.0	
Chain guide (upper)	Bolt	M6 × 1.0	4	10	1.0	
Chain guide (intake)	Plug	M10 × 1.25	1	10	1.0	
Oil pump	Screw	M6 × 1.0	2	10	1.0	
Oil pump	Bolt	M6 × 1.0	3	10	1.0	
Oil strainer housing	Bolt	M6 × 1.0	2	10	1.0	
Oil filter case	Union bolt	M20 × 1.5	1	15	1.5	
Oil pan	Bolt	M6 × 1.0	17	10	1.0	
Drain bolt (engine oil)	Plug	M14 × 1.5	1	43	4.3	
Oil gallery blind plug	Plug	M16 × 1.5	1	8	0.8	
Drain filter	Screw	M5 × 0.8	1	7	0.7	
Oil delivery pipe (oil pan)	Bolt	M6 × 1.0	4	10	1.0	
Oil delivery pipe (oil cooler)	Bolt	M6 × 1.0	4	10	1.0	
Oil cooler	Bolt	M6 × 1.0	2	10	1.0	
Oil cooler cover	Bolt	M6 × 1.0	4	8	0.8	
Oil delivery pipe (clamp)	Bolt	M6 × 1.0	1	10	1.0	
Intake manifold	Bolt	M6 × 1.0	8	10	1.0	
Air filter case cap	Bolt	M5 × 0.8	4	5	0.5	
Air filter case	Bolt	M6 × 1.0	3	7	0.7	
Exhaust pipe	Nut	M8 × 1.25	8	25	2.5	
Muffler and stay	Bolt	M8 × 1.25	2	20	2.0	
Exhaust chamber	Bolt	M10 × 1.25	1	25	2.5	
Exhaust pipe and exhaust chamber	Screw	M8 × 1.25	4	20	2.0	
Exhaust chamber and muffler	Bolt	M8 × 1.25	2	20	2.0	
Exhaust pipe blind plug (CO test)	Bolt	M6 × 1.0	4	10	1.0	
Bearing holder (main axle)	Screw	M6 × 1.0	3	12	1.2	
Timing plate cover	Bolt	M6 × 1.0	4	7	0.7	
Crankcase cover (right)	Screw	M5 × 0.8	2	4	0.4	
Clutch cover	Bolt	M6 × 1.0	11	10	1.0	
Drive sprocket cover	Bolt	M6 × 1.0	3	10	1.0	
Clutch release cylinder	Bolt	M6 × 1.0	3	10	1.0	
Crankcase	Bolt	M6 × 1.0	16	12	1.2	

MAINTENANCE SPECIFICATIONS

SPEC



Part to be tightened	Part name	Thread size	Q'ty	Tightening torque		Remarks
				Nm	m•kg	
Crankcase	Bolt	M8 × 1.25	17	24	2.4	
Crankcase	Bolt	M10 × 1.25	5	35	3.5	
Main gallery	Plug	M20 × 1.5	3	12	1.2	
Oil baffle plate	Bolt	M5 × 0.8	3	4	0.4	
Stopper plate	Bolt	M6 × 1.0	1	10	1.0	
Bearing housing	Screw	M6 × 1.0	3	10	1.0	
HY-VO chain guide	Bolt	M6 × 1.0	2	10	1.0	
Clutch boss	Nut	M20 × 1.5	1	70	7.0	
Clutch pressure plate	Bolt	M6 × 1.0	6	8	0.8	
Push lever comp.	Bolt	M6 × 1.0	2	10	1.0	
Drive sprocket	Nut	M22 × 1.5	1	85	8.5	
Shift shaft stopper	Screw	M8 × 1.25	1	22	2.2	
Stopper plate (Starter clutch idle gear shaft)	Screw	M6 × 1.0	2	7	0.7	
Stopper lever	Bolt	M6 × 1.0	1	10	1.0	
Side plate	Screw	M5 × 0.8	1	4	0.4	
Shift arm	Bolt	M6 × 1.0	1	10	1.0	
Shift lod	Nut	M6 × 1.0	2	8	0.8	
A.C. generator	Bolt	M8 × 1.25	2	25	2.5	
Oil level sensor	Bolt	M6 × 1.0	2	10	1.0	
Rotor	Bolt	M10 × 1.25	1	45	4.5	